

INSTALLATION INSTRUCTIONS

WARNING

- This product must be installed in accordance with the applicable installation code by a person familiar with the construction and operation of the product and the hazards involved.
- In order to avoid the danger of electric shock, make certain that the power supply is disconnected before installing or performing maintenance.
- Ensure all mounts are securely attached and will support the weight of the fixture. Failure to properly support fixture may result in damage or injury, for which the manufacturer does not assume responsibility.

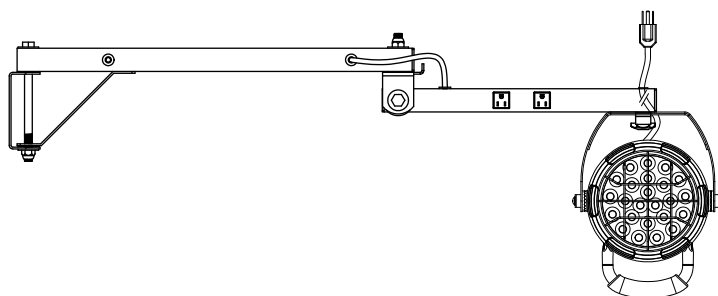

MOUNTING

1. Drill holes for mounting arm and securely mount it.
2. Route power cord

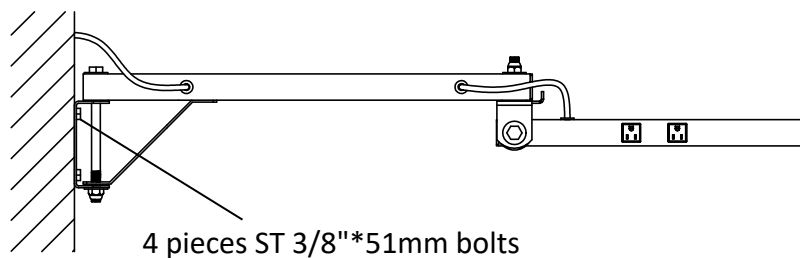
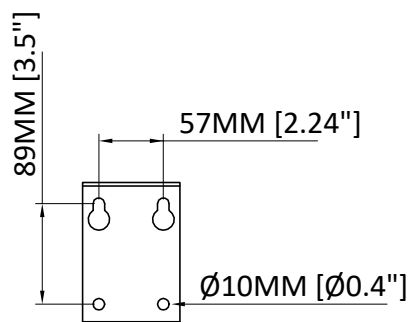

3. Securely attach light to arm.
4. Connect power cord to arm receptacle.

